

Top View

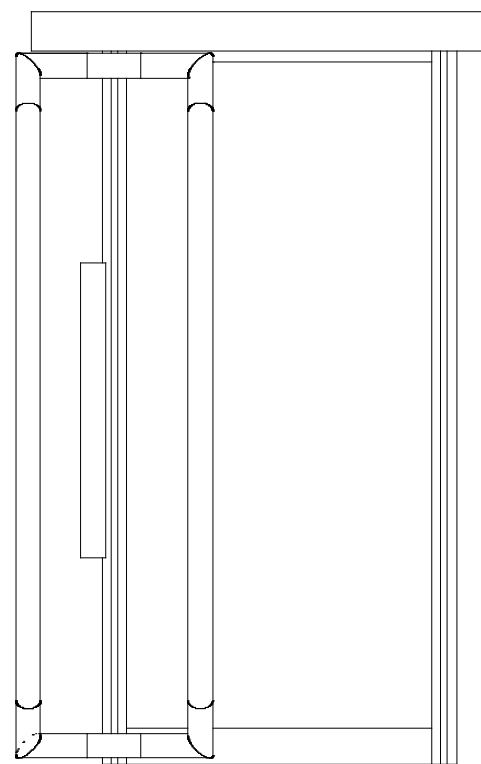

Side View

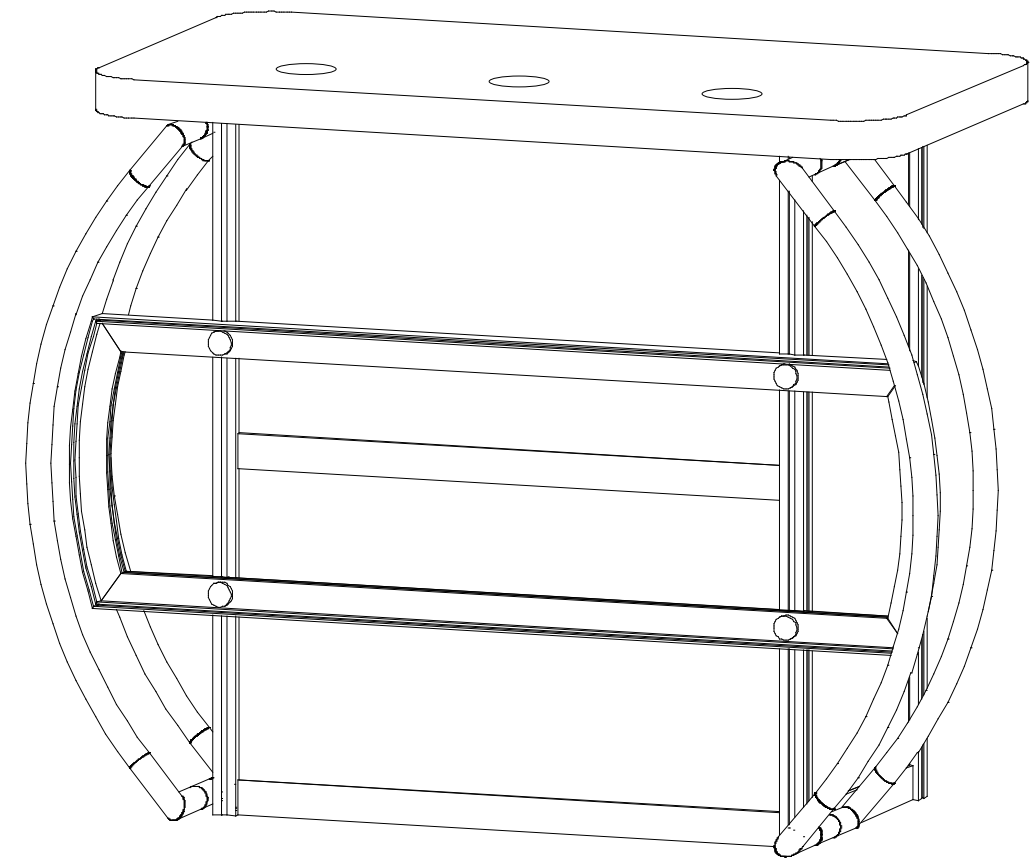

Perspective View

SETUP INSTRUCTIONS

General Setup Instructions

- Read entire setup instruction manual prior to unpacking parts and pieces.
- The setup instructions are created specifically for this configuration.
- Setup instructions are laid out sequentially in steps, including exploded views with detailed explanation for assembly.

Cleaning & Packing

- For Cleaning Metal, Plex, & Laminate Parts: Use a **MILD NON-ABRASIVE** cleanser and soft cloth/paper towel to clean all surfaces.
- Keep exhibit components away from heat and prolonged sun exposure.
Heat and UV exposure will warp and fade components.
- Retain all provided Packing Materials. All provided packing materials are for ease of repacking & component protection.

Disassembly

- For loss prevention, tighten all set screws and locks during disassembly.

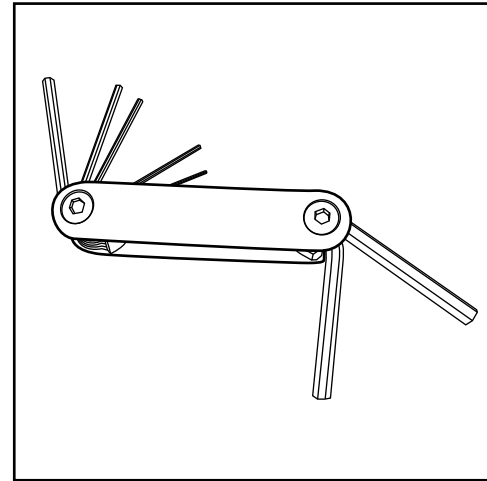

Hex Tool - Essential for Assembly

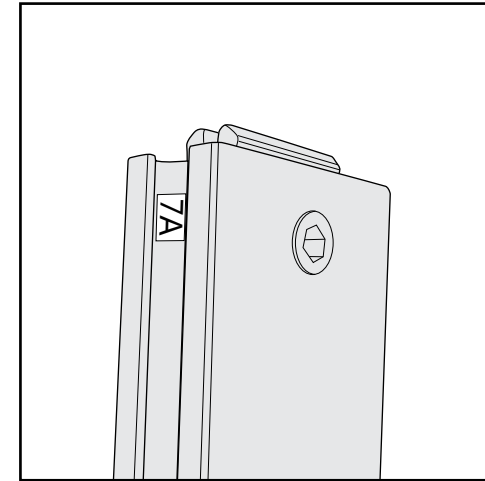

Part Identification - Numbering

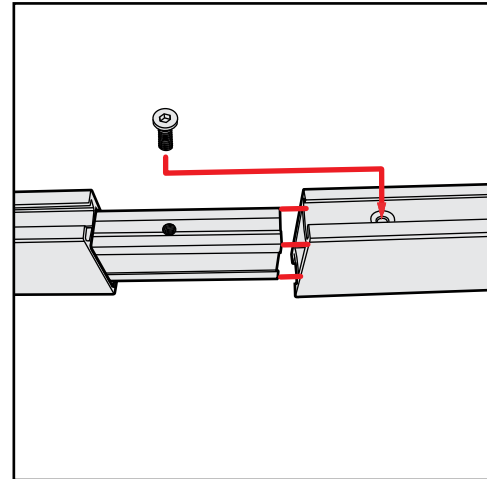

Spline Connection

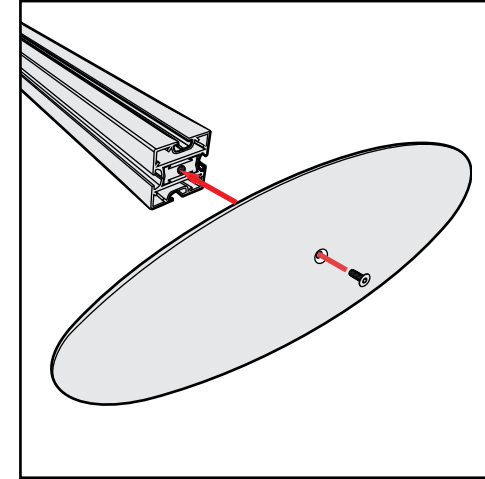

Base Plate & Extrusion Connection

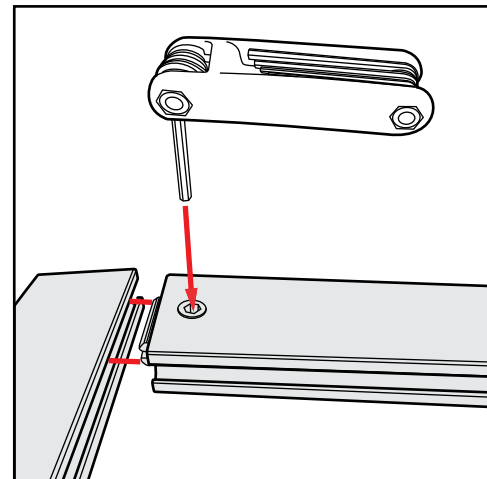

Extrusion & Lock Connection

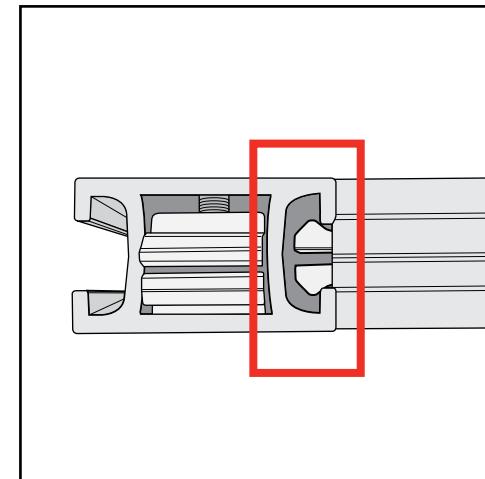

Engaged Lock



WARNING



DO NOT USE POWER TOOLS

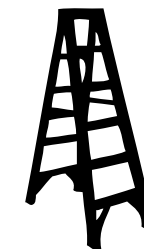

LADDERS OR LIFTS
MAY BE REQUIRED



ALL CONNECTIONS MUST
BE TIGHTLY SECURED

Item	Qty.	Description
1	1	37.5" S40 Vertical Extrusion w/ Door Hinge
2	1	37.5" S40 Vertical Extrusion
3	1	37.5" S40 Vertical Extrusion
4	1	37.5" S40 Vertical Extrusion w/ Door Hinge
5,5A	1,1	15.48" Z45 Horizontal Extrusion
6,6A	1,1	29.48" Z45 Horizontal Extrusion
7,7A,7B	1,1,1	29.48" Z45 Horizontal Extrusion
8	1	33.917" Z45 Vertical Extrusion w/ Door Stops

Steps:

- 1) Connect lower horizontals [5] [6] and [7] between verticals [1] [2] [3] and [4].
- 2) Slide lower infill between verticals [2] and [3] then secure with horizontal [7A].
- 3) Slide infills between verticals [1] [2], [2] [3] and [3] [4] then secure with upper horizontals [5A] and [7B], making sure Velcro is facing inward.
- 4) Attach vertical [8] to lower horizontal [6].
- 5) Connect doors to verticals [1] and [4]. See **Door Connection** detail.
- 6) Connect upper horizontal [6A] between verticals [1] and [4] and attach to vertical [8].
- 7) Connect **shelf supports** to Velcro on infills, then place shelf on top of supports.

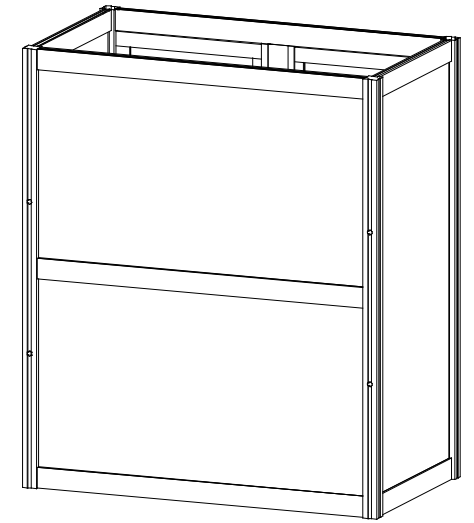

Partial Assembly

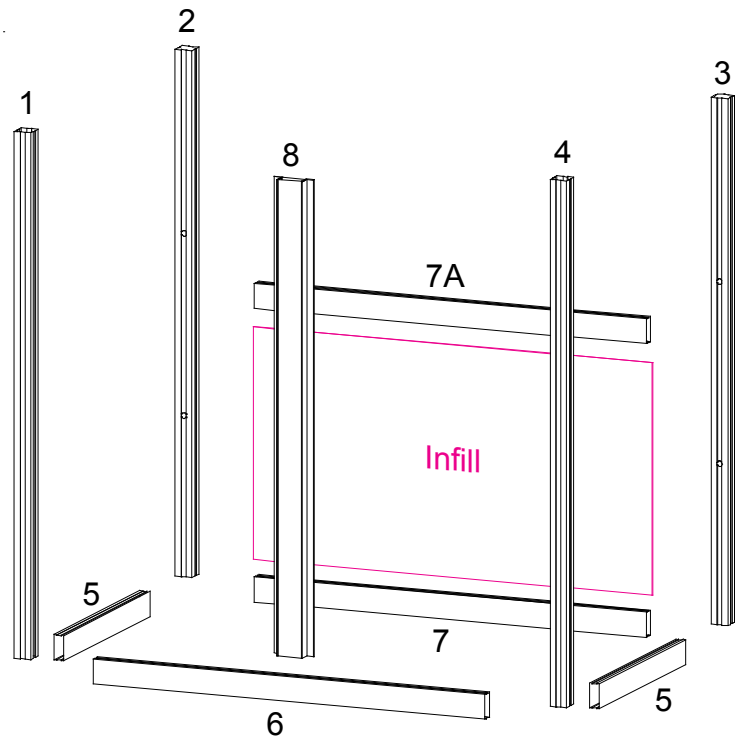

BACK VIEW

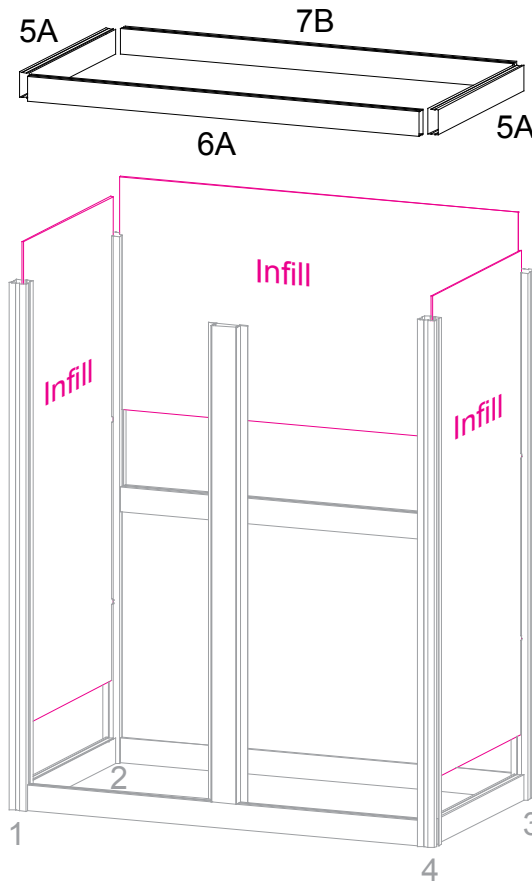

BACK VIEW

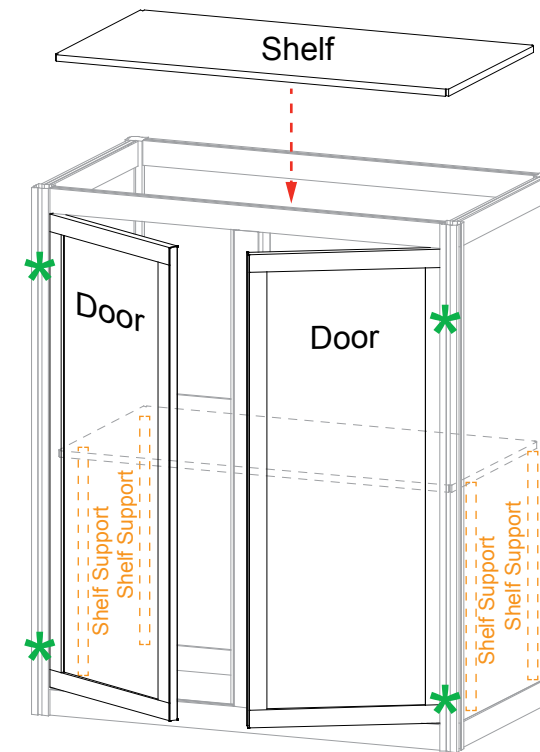

BACK VIEW

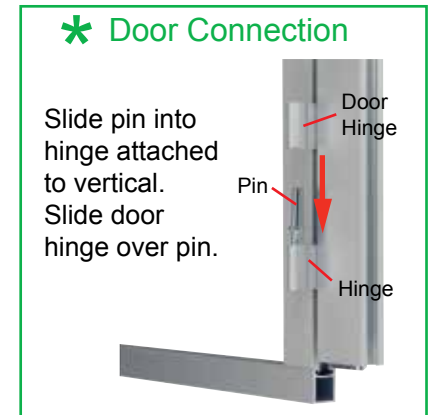

AERO

Using Your Setup Instructions

The Aero Setup Instructions are created specifically for your configuration. The instructions include an exploded view of the frame which is sequentially labeled. We encourage you to review the instructions before attempting to assemble your exhibit.

Connections are kept very simple; no tools required. Everything assembles with push-button connectors.

Cleaning and Packing Your Display

- 1) Use care when cleaning aluminum extrusion or acrylic inserts. Use only non-abrasive cleaners.
- 2) Retain all packing material. It will make re-packing much easier and will reduce the likelihood of shipping damage.

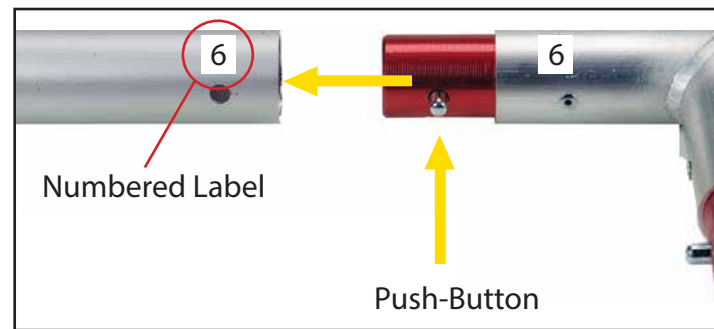

Connections are made by holding the button down and sliding the red tube into opposing tube until button locks into the hole of the opposing tube. To disassemble, push button and pull or twist extrusions apart.

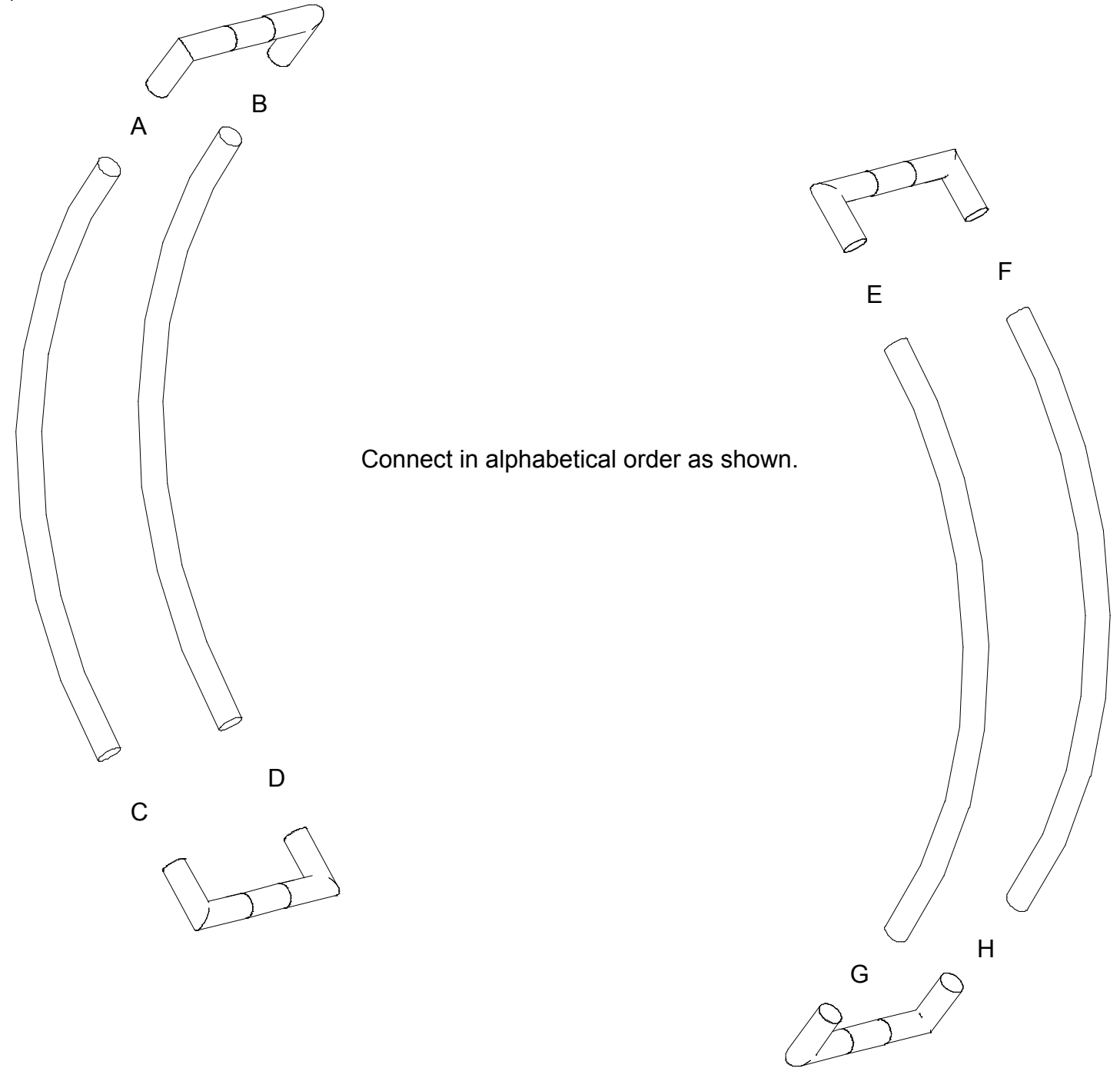
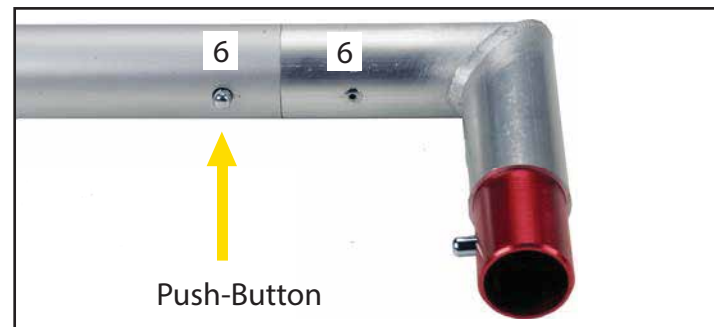

Item	Qty.	Description
9,9A	1,1	15.28" TSP46 Curved Vertical
10,10A	1,1	44.148" TSP46 Horizontal Extrusion

- Steps:
- 1) Assemble graphic frame as shown.
 - 2) Slide Aero frames into outer grooves of verticals [1] and [4].
 - 3) Attach graphic frame to verticals [1] and [4]. See [Graphic Frame Attachment](#) detail.
 - 4) Apply SEG graphics to graphic frame. See SEG Graphic Installation sheet for instruction.
 - 5) Lock counter top to horizontals [5A]. See [Counter Top Lock](#) detail.

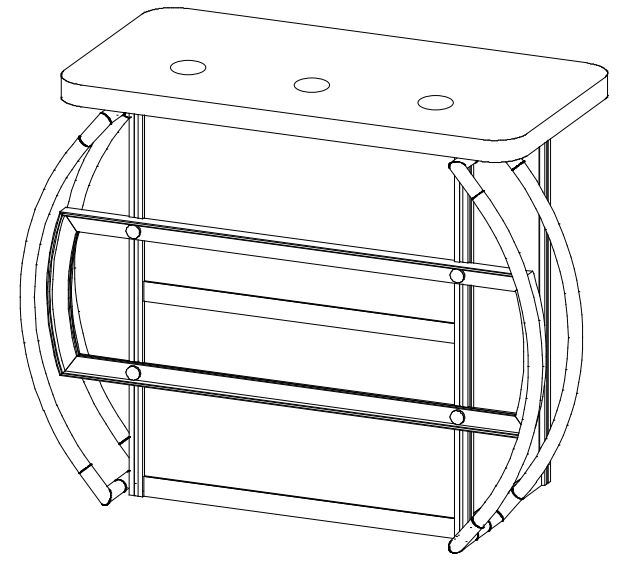

Completed Assembly

*** Graphic Frame Attachment**

Slide V4 connector into groove of vertical extrusion. Tighten set screw to secure V4 connector in place. Attach graphic frame to connector, using screw cap. Tighten screw cap to secure.

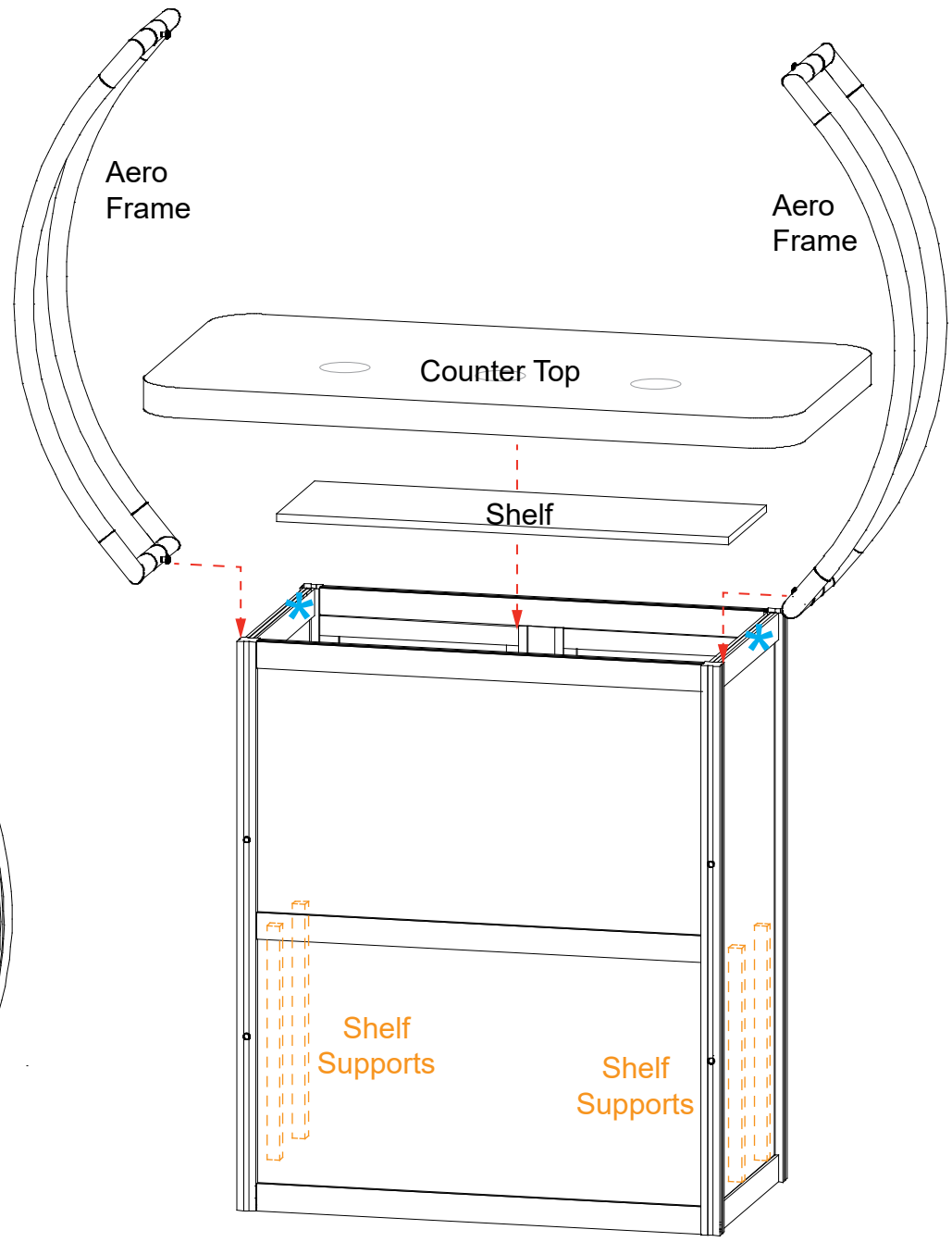

*** Counter Top Lock**

1. Align hole with pin

2. Rotate pin. Spring will push pin into hole.

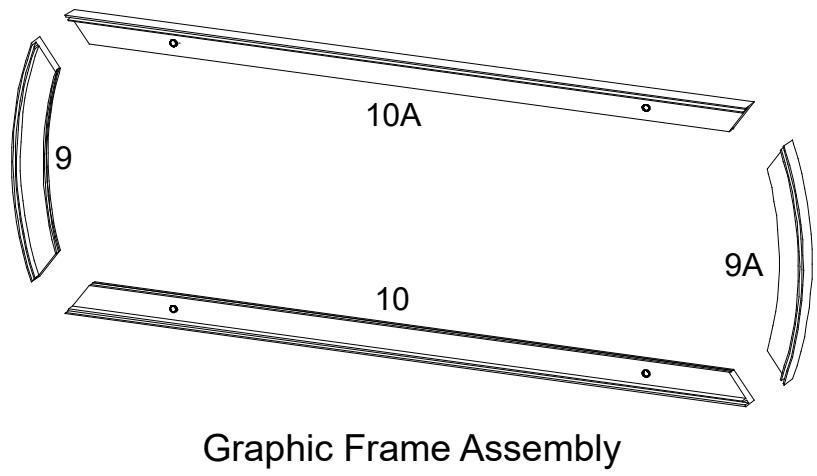

Graphic Frame Assembly

